

Card reader

PART #: SMB-Z041A-A00

KEY FEATURES

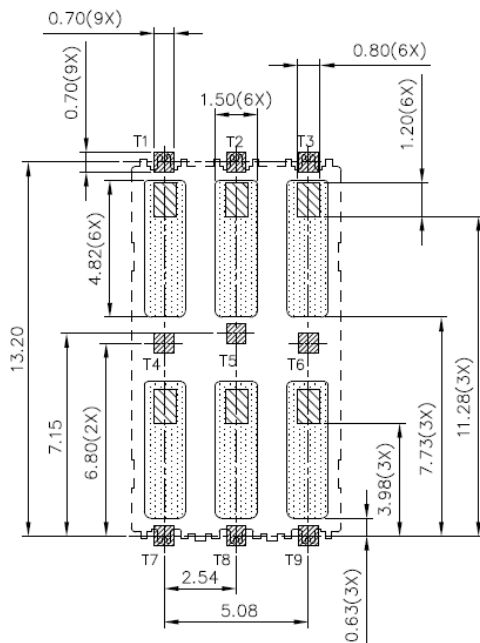

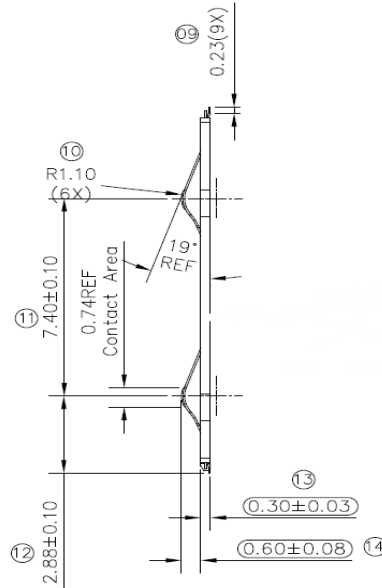
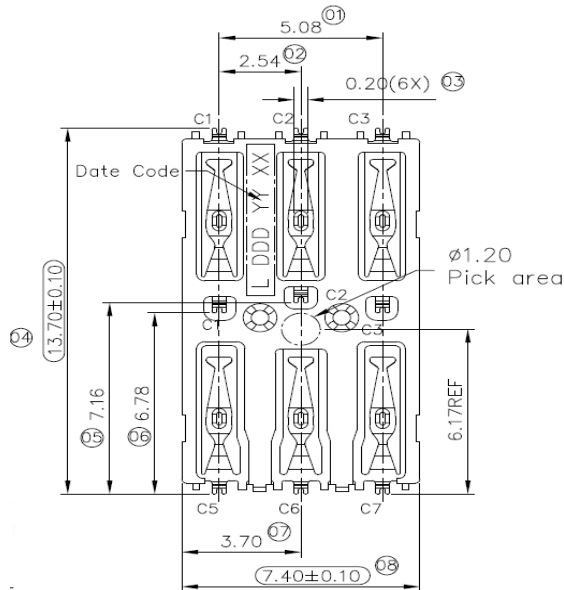

- 13.70Lx7.40Wx0.90H mm
- Stable contact force
- Contact force : 0.20N min
- Contact with Anti-scratching mechanism



PIN	NAME
T1, T4	Vcc
T2, T5	RST
T3, T6	CLK
T7	GND
T8	Vpp
T9	I/O

Recommend PCB Layout

Recommend tolerance: ±0.05

-  Soldering Pad area
-  Open Wire Restricted area (possibly touch of componets on PCB)
-  Connector outline
-  None Soldering Pad Area
 - 1.Touch Area of Contact Tips, No Electrical Function And Only For Mechanical Function.
 - 2.Don't Brush Tin Pasted On The Area During SMT Process